

A 60 GHz Wide-Band Communication Module that also Supports the New 5G Band

Ryohei Hosono,¹ Ryohei Sugiura,¹ Norito Tomimizu,¹ Masaki Sono,¹ Shinya Abe,¹ and Kiyoshi Kobayashi¹

We have developed a 60 GHz wide-band communication module that covers the entire 60 GHz band including the new 5G band for FWA, wireless back-haul, enterprise, and V2X applications. We also have evaluated the module in indoor and outdoor environments and it has satisfied requirements for above applications.

1. Introduction

Recently, high-speed, high-capacity networks have become essential for all kinds of communication. In particular, high-speed, high-capacity wireless networks are considered one of the key technologies for Industry 4.0 and will have wide-ranging applications in addition to conventional ones in the near future. Among current wireless networks, Wi-Fi, especially, is expected to be applied to broader areas because of its convenience. Wi-Fi for the next generation is required to offer high-speed, reliability, low latency and multiple connections, but conventional Wi-Fi systems that operate in bands including 2.4 GHz and 5 GHz cannot meet the requirements due to their limited bandwidths. Thus, for the next-generation Wi-Fi, the use of millimeter wave (mmWave) is indispensable, and 60 GHz-mmWave (57-71 GHz) is regarded as one of the major candidates. The standard for 60 GHz-mmWave Wi-Fi, IEEE 802.11ad [1], includes a wide channel bandwidth (2.16 GHz), TDMA and high-directivity beamforming. These features will satisfy demand for high-speed, huge-capacity wireless networks. IEEE 802.11ad-based wireless networking is expected to be applied in use-cases in indoor and outdoor environments. The use-cases include fixed wireless access (FWA), wireless back-haul, enterprise, and V2X. In fact, some kinds of proof of concept (PoC) have already been carried out [2]. It is assumed that mmWave communication will contribute significantly not only to improving conventional technologies in current application areas but also to opening up new applications in the near future.

Fujikura has developed a 60 GHz wide-band communication module that covers the entire 60 GHz band including the new 5G band for above-mentioned applications and also evaluated the module in indoor and outdoor environments.

2. 60 GHz wide-band communication module

Figure 1 shows the external view of the newly-developed 60 GHz wide-band communication module. This product is a device-embedded communication module that integrates a wireless protocol processing (baseband) function and a radio frequency (RF) circuit function including an antenna.

The antenna and wireless IC (RF-IC) are mounted on a substrate made of a low-loss liquid crystal polymer (LCP) material to minimize transmission loss due to wiring. The antenna has 4 x 16 phased array antenna elements and a high antenna gain of up to 21 dBi. In addition, its beamforming function allows a wide communication coverage of ± 45 degrees in the horizontal direction. The baseband IC (BB-IC) performs digital baseband signal processing and communication protocol processing based on IEEE 802.11ad. The communication interface with the device is PCIe 2.0.

Figure 2 shows the functional block diagram. Table 1 shows the major specifications.

Table 1. Major specification for module.

Frequency Band	57-71 GHz(CH1-CH6)
EIRP	40 dBm
Horizontal Beam Forming Angle	± 45 deg
Interface	PCIe Gen2 x 2 lane

3. Unit testing

To evaluate the transmission performance of the 60 GHz-wideband communication module, its equivalent isotropically radiated power (EIRP) including the beamforming characteristics was measured. Figure 3 shows the EIRP measurement results. The beamforming is designed so that 64 patterns of antenna directions can be set. Since a high-gain antenna with high directivity is used, the beam width in the horizontal direction is narrowed to about 8 to 9 degrees while the coverage is expanded to ± 45 degrees by the beamforming.

¹ : Wideband Radio System Development Department

Panel 1. Abbreviations, Acronyms, and Terms.

TDMA—Time Division Multiple Access
access method dividing time slots with one carrier for multiple users

V2X—Vehicle to X
Communication among vehicle, other vehicles, people etc.

EIRP—Effective Isotropic Radiated Power
Metric expressed by product of input power to antenna and absolute gain in desired direction

NPU—network processing unit
processor dedicated for network control

P2P—point-to-point
configuration for single access point and single station

PCP/AP—PBSS central point/access point
control terminal for Wi-Fi

STA—station
slave device for Wi-Fi

UDP—user datagram protocol
for transferring data to layer 4 without providing delivery guarantee to the receiver

MCS—modulation and coding scheme
expressed by combining code rate and modulation

Phased Array Antenna

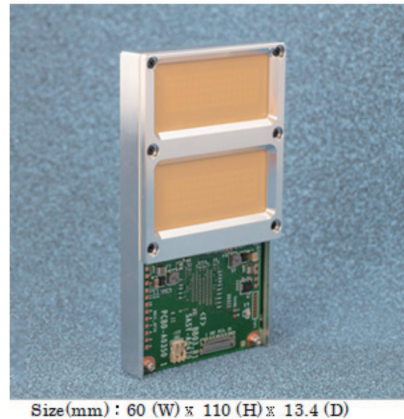
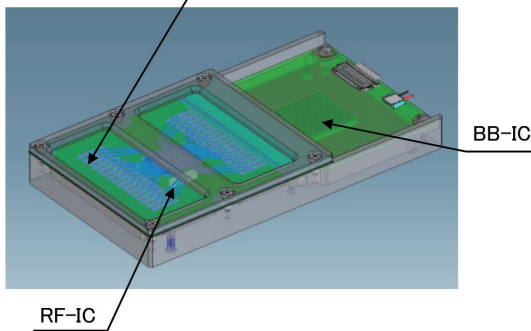

Size(mm) : 60 (W) x 110 (H) x 13.4 (D)

Fig.1. A 60 GHz wide-band communication module.

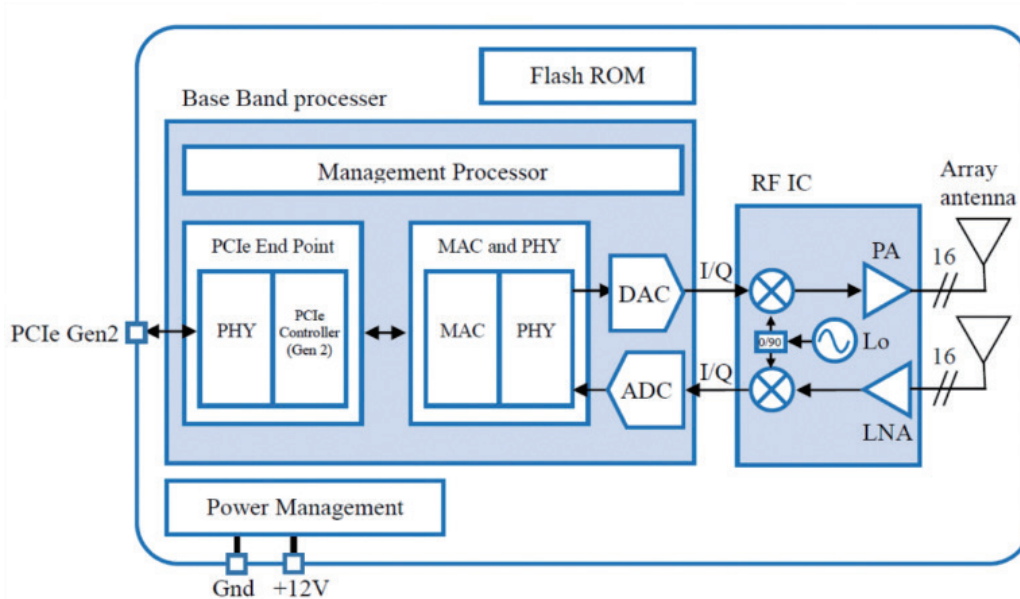

Fig. 2. Functional Block diagram.

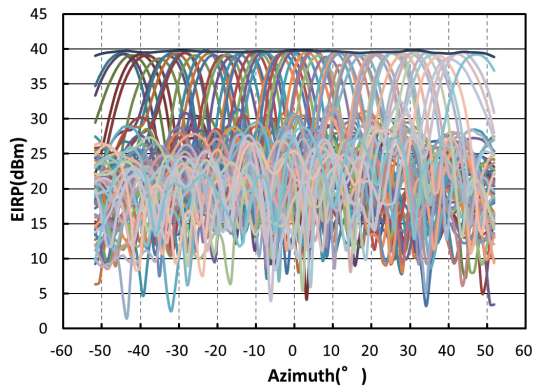

Fig. 3. Beamforming characteristics.

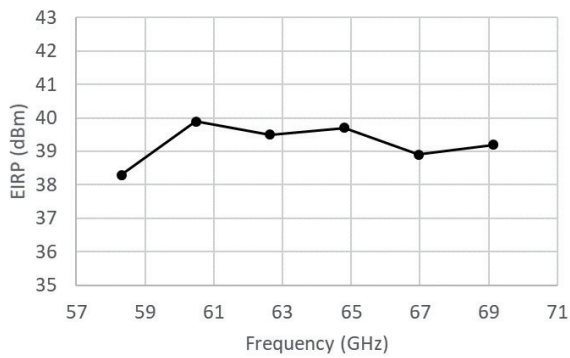

Fig.4. Frequency characteristics of EIRP.

Furthermore, as shown in Fig. 4, the frequency characteristics of EIRP were also measured. The measurement results show that our module can cover the wide frequency band of 57 to 71 GHz, which is standardized in IEEE 802.11 ad.

4. System-level testing

To evaluate the quality of communication that uses the 60 GHz wide-band communication module, the module was integrated with a network processing unit (NPU). Figure 5 shows the 60 GHz wide-band communication module mounted on a chassis. The chassis has a width of 300 mm, height of 300 mm, and depth of 250 mm. The chassis also includes a power supply unit for the overall system in addition to the module and NPU. For the system-level evaluation, a point-to-point (P2P) network was configured with a PBSS central point/access point

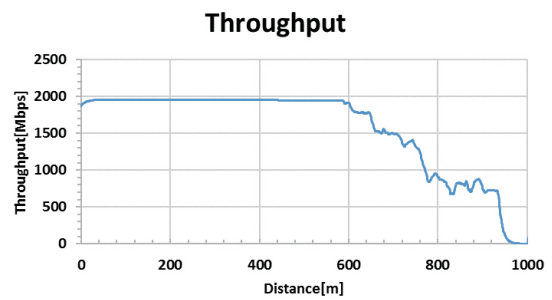

Fig. 5. 60 GHz wide-band communication module mounted on chassis.

(PCP/AP) and station (STA) based on [1]. In measuring wireless throughput, user datagram protocol (UDP) traffic was generated, and channel 4 (63.72-65.88 GHz) was employed. Figure 6 shows a view of a field trial with the system. The installation height was set at 3 m. Figure 7 shows the dependence of throughput and received modulation and coding scheme (MCS) index on distance in the field trials. A minimum and maximum distance (0-1000 m) were set based on possible applications in 60 GHz and new 5 G bands and the results of link budget analysis (using calculation of electrical characteristics of transceiver and path loss). The maximum value of MCS index was set at 9 for reasons of the released software version. The 60 GHz wide-band communication module has been confirmed to enable a wireless throughput of 2.0 Gbps to be maintained stably under P2P transmission up to a distance of 500 m. The module has also achieved a maximum wireless communication distance of 1000 m. The periodic bottoms of the received MCS indexes at a distance of 600 m or more reflect the reduction in the power obtained by combining direct waves and ground-reflected waves, as expected. Finally, 60 GHz long-distance communication, which could not have been



Fig. 6. Overall view of the module in field trial.



a : Dependence of throughput on distance.

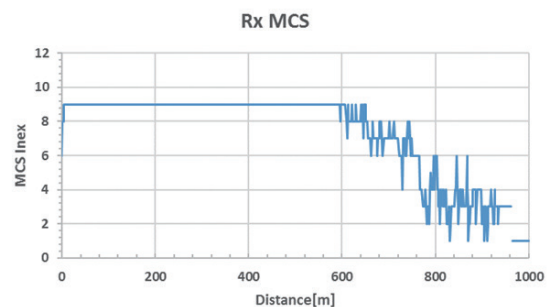

b : Dependence of MCS index on distance.

Fig. 7 Dependence of throughput and MCS index on distance.

achieved using conventional Wi-Fi systems, was successfully performed using a multi-gigabit, high-capacity wireless-network.

5. Conclusion

This paper has described the development and evaluation of a 60 GHz wide-band communication module. The newly developed module is compact in size and offers good performance at overall frequency bands. The module has also provided higher throughput in a long-range deployment, which cannot be achieved in conventional Wi-Fi.

System integration in response to customer demand, and further evaluation of the module on the assumption of promising use-cases will be conducted in the near future.

References

- 1) URL : http://www.ieee802.org/11/Reports/tgad_update.htm,
- 2) URL : https://terragraph.com/wp-content/uploads/2020/06/FBC19-004_Terragraph-Whitepaper-for-TIP-2019_R2.pdf