

# Analog Output Semiconductor Pressure Sensor

# AG2 Series

## Description

The AG2 pressure sensor series is composed of a silicon piezoresistive pressure sensing chip and a signal conditioning integrated circuit. The low-level signal from the sensing chip is amplified, temperature compensated, calibrated and finally converted to a high level analog output voltage that is proportional with the applied pressure. The AG2 series measures gauge pressure.

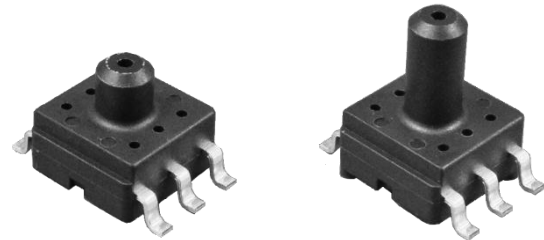

AG2\*3

AG2\*6

## Features

- Amplified and temperature compensated analog output
- High accuracy  $\pm 1.5\%$ FS
- Supply voltage 3.0, 3.3 & 5.0 Vdc
- Low supply current Max 2 mA at 3.3 Vdc
- Miniature 10.3 mm x 7 mm SMT package
- 3 mm port and 6 mm port available
- Operating temperature -40 to 125°C
- Wide compensated temperature 0 to 85°C
- Pins & Package compatible with Fujikura's XFGM integrated pressure sensor
- Customization available

## Applications

- Battery-operated Devices
- Medical Devices
- Industrial Pneumatic Devices
- Consumer Devices

**RoHS Compliant**

## Device Lineup

Model	Port Length	Pressure Type	Supply Voltage	Accuracy	Pressure Range										
					-100	-50	0	25	50	100	200	500	700	1000 kPa	
					(-15)	(-7)	(3)	(7)	(15)	(30)	(70)	(100)	(150) psi		
AG2	6 mm or 3 mm	Gauge	5.0 Vdc or 3.3 Vdc	$\pm 1.5\%$ FS											
			3.0 Vdc	$\pm 2.0\%$ FS	Same as the above										

# Analog Output Semiconductor Pressure Sensor

# AG2 Series

## Device Name Code

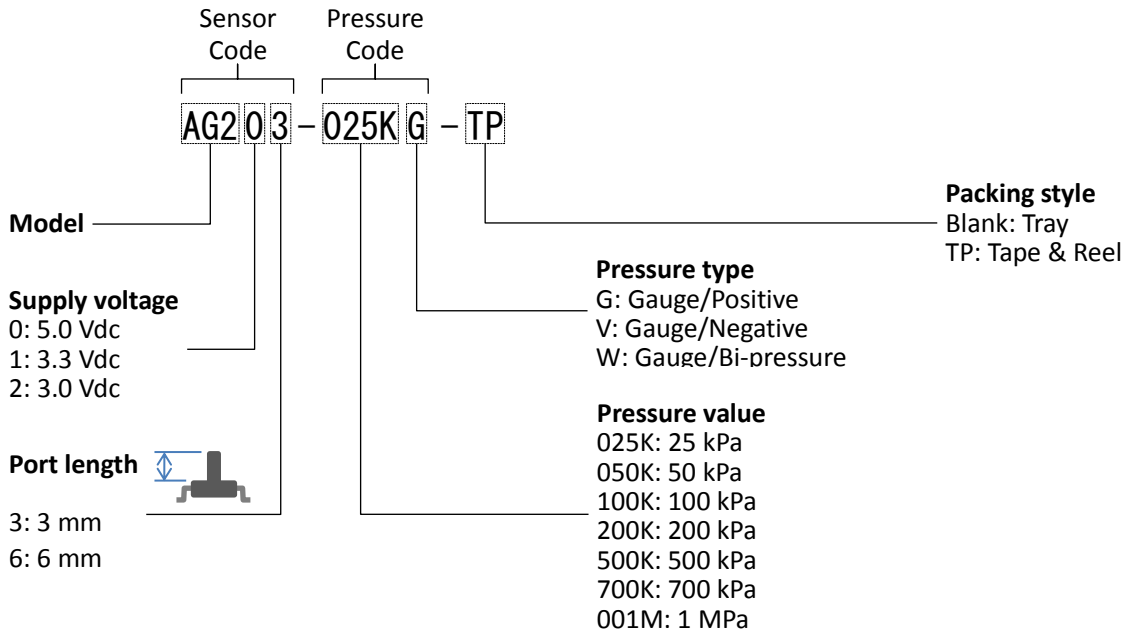

## Block Diagram

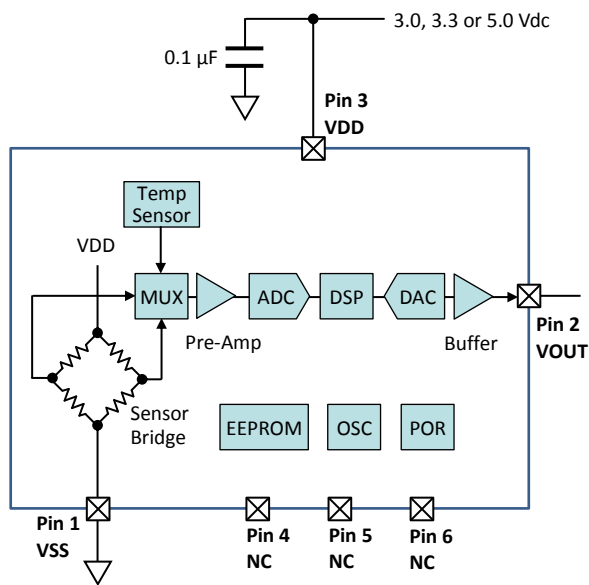

## Output Characteristics

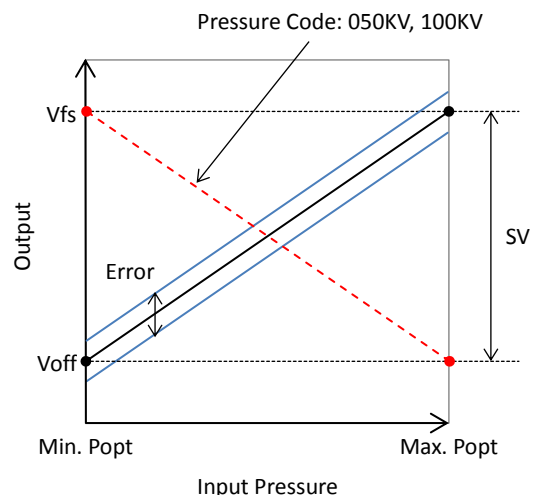

# Analog Output Semiconductor Pressure Sensor

# AG2 Series

## Absolute Maximum Ratings

Item	Symbol	Rating	Unit
Supply Voltage	VDDmax	6	Vdc
Load Pressure	Pmax+	See Pressure Range Table	
Operating Temperature	Topt	-40 to +125	°C
Storage Temperature	Tstg	-40 to +125	°C

## General Specifications

Item	Symbol	Sensor Code			Unit
		AG20*	AG21*	AG22*	
Supply Voltage	VDD	5.0±0.25	3.3±0.165	3.0±0.15	Vdc
Type of Pressure	-	Gauge pressure			
Pressure Media	-	Non-corrosive gases			
Compensated Temperature	-	0 to +85			°C
Operating Humidity	Hopt	30 to 85 (non-condensing)			%RH
Storage Humidity	Hstg	30 to 85 (non-condensing)			%RH

## Pressure Range

Item	Symbol	Pressure Code										Unit
		025KG	050KG	100KG	200KG	500KG	700KG	001MG	050KV	100KV	100KW	
Absolute Maximum Load Pressure	Pmax+	+50	+100	+200	+400	+1000	+1400	+1500	+100	+200	+200	kPa
Measurement Pressure	Popt	Min.	0	0	0	0	0	0	-50	-100	-100	
		Max.	+25	+50	+100	+200	+500	+700	+1000	0	0	

## Electrical Characteristics

Load resistor  $R_L = \infty$ , Ambient temperature  $T_a = 25^\circ\text{C}$ 

Sensor Code	Item	Condition	Symbol	Rating			Unit	
				Min.	Typ.	Max.		
AG20* VDD = 5.0 Vdc	Offset Voltage	Min. Popt, 050KV & 100KV: Max. Popt	Voff	0.1325	0.2	0.2675	V	
	Full Scale Voltage	Max. Popt, 050KV & 100KV: Min. Popt	Vfs	4.6325	4.7	4.7675	V	
	Span Voltage	Min. to max. Popt	SV	-	4.5	-	V	
	Accuracy	0 to 85°C	Error	-1.5	-	+1.5	%FS	
					-0.0675	-	+0.0675	V
	Output Resolution		Vrso	-	2.5	-	mV	
	Supply Current		Ic	-	-	3	mAdc	
AG21* VDD = 3.3 Vdc	Offset Voltage	Min. Popt, 050KV & 100KV: Max. Popt	Voff	0.2595	0.3	0.3405	V	
	Full Scale Voltage	Max. Popt, 050KV & 100KV: Min. Popt	Vfs	2.9595	3.0	3.0405	V	
	Span Voltage	Min. to max. Popt	SV	-	2.7	-	V	
	Accuracy	0 to 85°C	Error	-1.5	-	+1.5	%FS	
					-0.0405	-	+0.0405	V
	Output Resolution		Vrso	-	1.7	-	mV	
	Supply Current		Ic	-	-	2	mAdc	
AG22* VDD = 3.0 Vdc	Offset Voltage	Min. Popt, 050KV & 100KV: Max. Popt	Voff	0.096	0.15	0.204	V	
	Full Scale Voltage	Max. Popt, 050KV & 100KV: Min. Popt	Vfs	2.796	2.85	2.904	V	
	Span Voltage	Min. to max. Popt	SV	-	2.7	-	V	
	Accuracy	0 to 85°C	Error	-2.0	-	+2.0	%FS	
					-0.054	-	+0.054	V
	Output Resolution		Vrso	-	1.5	-	mV	
	Supply Current		Ic	-	-	2	mAdc	
Common	Response Time	for reference	tr	-	1	-	msec.	
	Sampling Frequency		fs	-	1	-	kHz	
	Load Resistor	VOUT - VSS or VDD - VOUT	RL	2.5	-	-	kΩ	
	Load Capacitance	VOUT - VSS	CL	-	-	15	nF	

# Analog Output Semiconductor Pressure Sensor

# AG2 Series

## Package Dimensions

unit: mm

### Sensor Code: AG2\*3

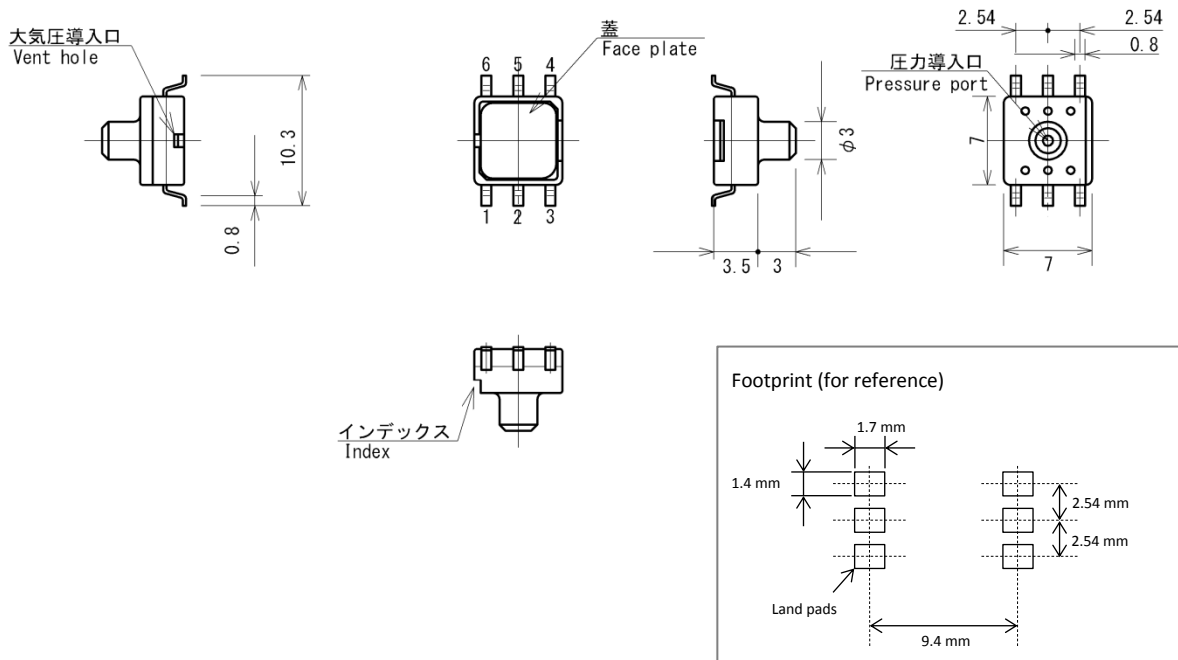

### Sensor Code: AG2\*6

